NI-9361

Specifications

2022-11-28



Contents

NI 9361 Datasheet..... 3

NI 9361 Datasheet

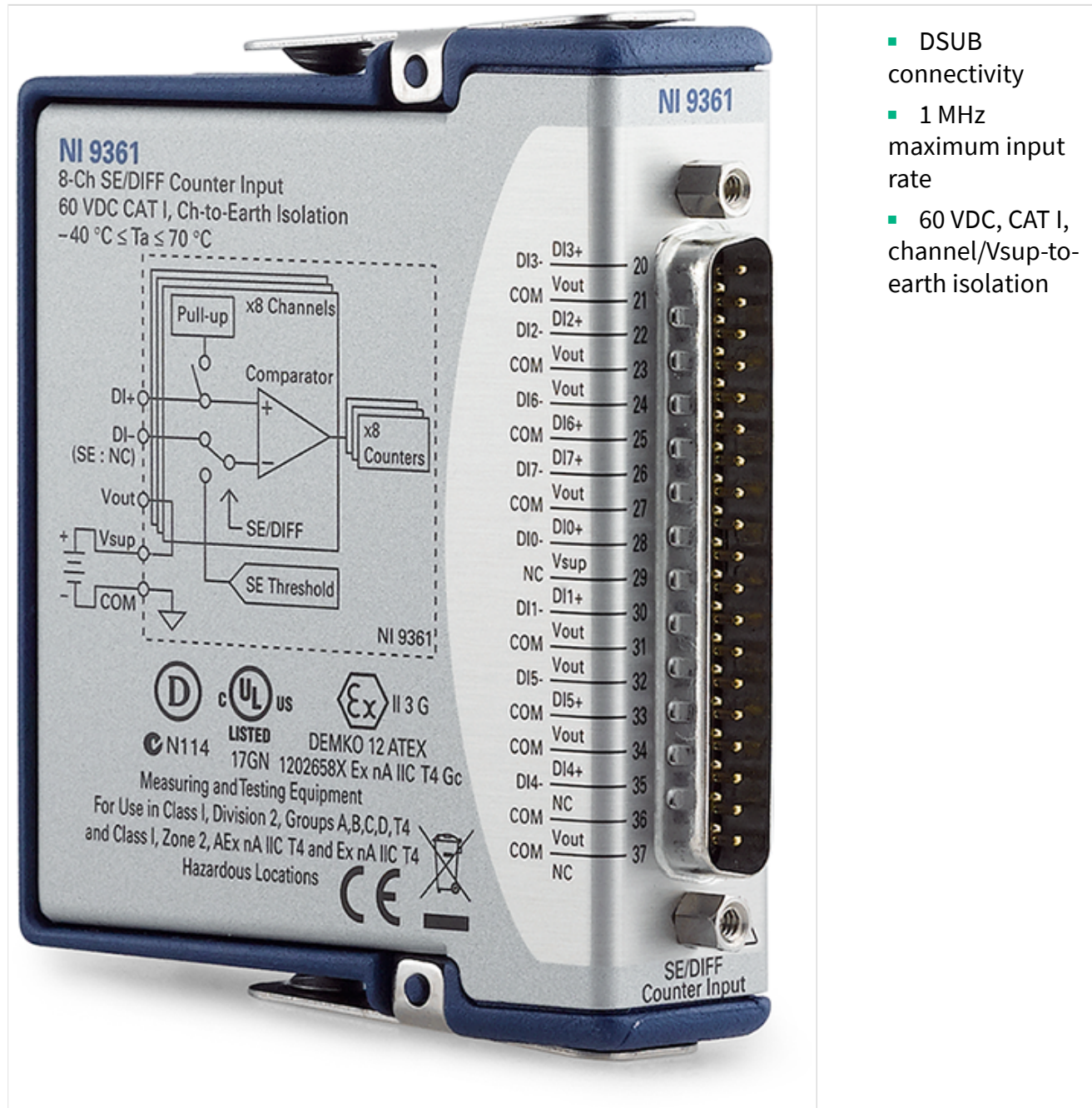

- DSUB connectivity
- 1 MHz maximum input rate
- 60 VDC, CAT I, channel/Vsup-to-earth isolation



The NI 9361 counter input module features 8 channels that you can configure as differential or single ended for a CompactDAQ or CompactRIO system. Each NI 9361

provides 8 embedded counters. This allows you to expand your CompactDAQ system beyond the 4 backplane counters.

You can configure each channel to read a single-pulse train or combine them together to read incremental encoders. You can also directly connect sensors with open-collector or push-pull outputs using the internal switchable 1 k Ω pull-up resistors and simplify your sensor wiring by routing sensor power through the module.

The NI 9361 32-bit counters are capable of standard counter measurements such as edge counting, pulse width, period, and frequency measurement as well as encoder position and velocity measurements. You can synchronize with analog, digital, and other counter measurements in your system with the NI 9361 counters.

The NI 9361 counters provide enhanced frequency and duty-cycle (PWM) measurements. For frequency measurements, the counters support a Dynamic Averaging mode allowing you to obtain frequency measurements that are optimized for accuracy and latency from 0 Hz up to high rates. For duty-cycle measurements, the counters can correctly measure over the full range from 0% to 100%.

	Kit Contents	<ul style="list-style-type: none">• NI 9361• NI 9361 Getting Started Guide
	Recommended Accessories	<ul style="list-style-type: none">• NI 9923 37-Pin DSUB to Screw-Terminal Connector Block

C SERIES COUNTER MODULE COMPARISON				
Product Name	Channels	Range	Channel Description	Input Rate
NI 9361	8	5 V Differential, 24 V Single Ended	Input	1 MHz
NI 9401	8	5 V, TTL	Input/Output	10 MHz
NI 9402	4	LVTTTL	Input/Output	16 MHz
NI 9411	6	5 V Differential, 24 V Single Ended	Input	1 MHz
NI 9421	8	30 V	Input	10 kHz
NI 9422	8	60 V	Input	4 kHz
NI 9423	8	30 V	Input	1 MHz
NI 9435	4	250 V	Input	333 Hz
NI 9437	8	250 V	Input	10 kHz

NI C Series Overview



NI provides more than 100 C Series modules for measurement, control, and communication applications. C Series modules can connect to any sensor or bus and allow for high-accuracy measurements that meet the demands of advanced data acquisition and control applications.

- Measurement-specific signal conditioning that connects to an array of sensors and signals
- Isolation options such as bank-to-bank, channel-to-channel, and channel-to-earth ground

- -40 °C to 70 °C temperature range to meet a variety of application and environmental needs
- Hot-swappable

The majority of C Series modules are supported in both CompactRIO and CompactDAQ platforms and you can move modules from one platform to the other with no modification.

CompactRIO



CompactRIO combines an open-embedded architecture with small size, extreme ruggedness, and C Series modules in a platform powered by the NI LabVIEW reconfigurable I/O (RIO) architecture. Each system contains an FPGA for custom timing, triggering, and processing with a wide array of available modular I/O to meet any embedded application requirement.

CompactDAQ

CompactDAQ is a portable, rugged data acquisition platform that integrates connectivity, data acquisition, and signal conditioning into modular I/O for directly interfacing to any sensor or signal. Using CompactDAQ with LabVIEW, you can easily customize how you acquire, analyze, visualize, and manage your measurement data.



Software

LabVIEW Professional Development System for Windows



- Use advanced software tools for large project development
- Generate code automatically using DAQ Assistant and Instrument I/O Assistant
- Use advanced measurement analysis and digital signal processing
- Take advantage of open connectivity with DLLs, ActiveX, and .NET objects
- Build DLLs, executables, and MSI installers

NI LabVIEW FPGA Module

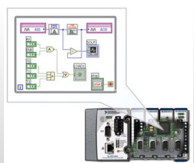

- Design FPGA applications for NI RIO hardware
- Program with the same graphical environment used for desktop and real-time applications
- Execute control algorithms with loop rates up to 300 MHz
- Implement custom timing and triggering logic, digital protocols, and DSP algorithms
- Incorporate existing HDL code and third-party IP including Xilinx IP generator functions
- Purchase as part of the LabVIEW Embedded Control and Monitoring Suite

NI LabVIEW Real-Time Module

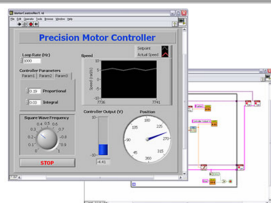

- Design deterministic real-time applications with LabVIEW graphical programming
- Download to dedicated NI or third-party hardware for reliable execution and a wide selection of I/O
- Take advantage of built-in PID control, signal processing, and analysis functions
- Automatically take advantage of multicore CPUs or set processor affinity manually
- Take advantage of real-time OS, development and debugging support, and board support

NI LabVIEW Real-Time Module

- Purchase individually or as part of a LabVIEW suite

Input Circuitry

The NI 9361 is a channel-to-earth isolated counter input module that provides 8 flexible digital input channels that route to 8 embedded counters. The inputs are designed for connection to encoders, hall-effect sensors, as well as many other types of sensors with digital outputs.

You can configure the front end of each channel individually to operate in differential or single-ended mode.

In single-ended mode, you can configure a programmable voltage threshold level and enable or disable an internal pull-up resistor.

Figure 1. NI 9361 Input Circuitry

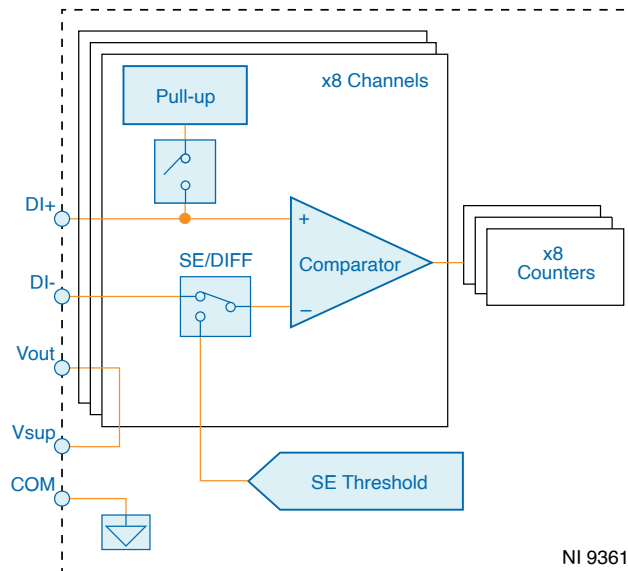

NI 9361 Front End Control

The NI 9361 has 8 inputs that support both single-ended and differential modes. You can configure each of the input signals as the input to any of the 8 counters on the

module. The following figure shows the circuitry of one of the digital inputs. Each digital input is similar.

Figure 2. Digital Input Circuitry

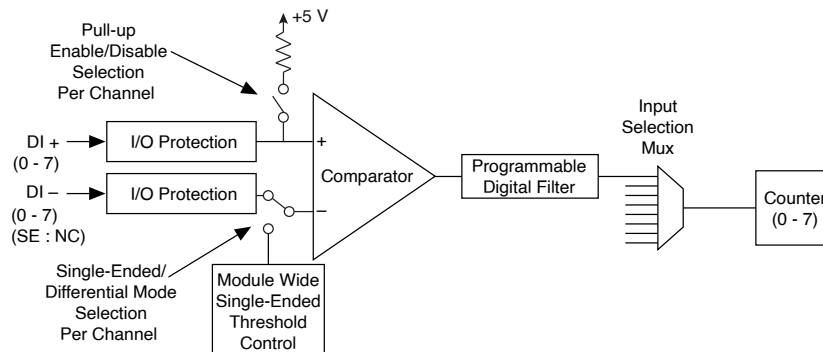

I/O Protection

The voltage input level and the current input level of the digital signals are listed in the specifications of your device. The I/O protection circuitry protects the module in events such as overvoltage, overcurrent, and ESD. Refer to the [Input Characteristics](#) section for more information about the protection level supported.

Input Mode

You can configure the digital inputs to any of the following modes:

- Single ended
- Single ended with pull up
- Differential



Note In single-ended and single-ended with pull-up modes, you must leave the corresponding DI- terminal open and connect the input signal to the corresponding DI+. You can set the programmable threshold voltage between 1 V to 4 V.

The NI 9361 provides a 5 V pull-up on each DI+ terminal which can be enabled individually. The 5 V pull up is about 1 k Ω , and is able to source up to about

5 mA of current to the sensor signal line connected to DI+. The pull up is useful for sensors with open-collector or open-drain outputs such as Hall Effect sensors. An open-collector device does not actively drive the signal high and relies on an external pull-up to perform this function.

In differential mode, there is no programmable threshold voltage. The 5 V pull up is disabled. The differential line signals are connected to the corresponding DI+ and DI- terminals.



Note Refer to the device **NI 9361 Getting Started Guide** on ni.com/manuals for wiring diagram examples of different sensors.

Programmable Digital Filter

The NI 9361 has a digital filter on each of the digital input lines to filter unwanted glitches on the digital input signal.

You can configure the following filter properties for each of the input lines:

- Enable or disable the digital filter.
- Minimum pulse width of the input signal that passes through the filter.

NI 9361 Counter Input Measurements

Edge Counting

You can take edge counting measurements with the NI 9361. The counter counts the number of active edges on a signal. The NI 9361 returns the current count value when the counter is read. The following figure shows an example of edge counting.

Figure 3. Edge Counting

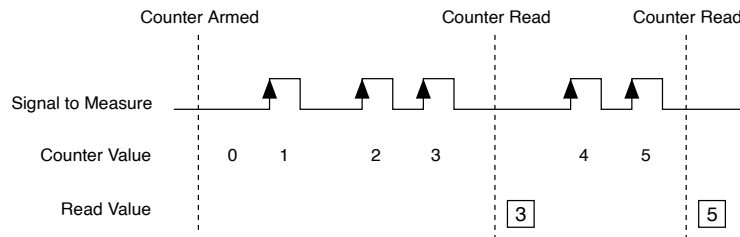

Channel Settings

You can configure the following counter properties:

- Input terminal of the signal-to-measure.
- The initial value of the count.
- The active edge, rising or falling, that is counted.
- Count direction to increment or decrement the counter on each edge. You can set this property to:
 - Count Up
 - Count Down
 - Externally Controlled



Note If you select Externally Controlled, the NI 9361 monitors a hardware signal to determine the count direction. When the signal is high, the counter counts up; when the signal is low, the counter counts down. You can set which signal to monitor.

- Counter Reset
 - You can configure the counter to reset the count to a specific value in response to a hardware signal using the following Reset Trigger properties:
 - Enable or disable the Reset Trigger feature.
 - Input terminal of the signal to be used as the Reset Trigger.
 - Reset Trigger active edge to select the rising or falling edge of the signal to trigger a reset.

- The reset value to change the count value to in response to the Reset Trigger.
- Count Edges Pause Trigger
 - You can configure the counter to pause counting based on a hardware signal using the following properties:
 - Enable or disable the Count Edges Pause Trigger feature.
 - Input terminal of the signal to be used as the Count Edges Pause Trigger.
 - Count Edges Pause Trigger level to select pause counting when the signal is high or low.

The following figure shows an example of a count edge measurement using the Reset Trigger with the initial value of the count value set to 6, Reset Trigger active edge set to rising edge, and the reset value set to 3.

Figure 4. Reset Trigger

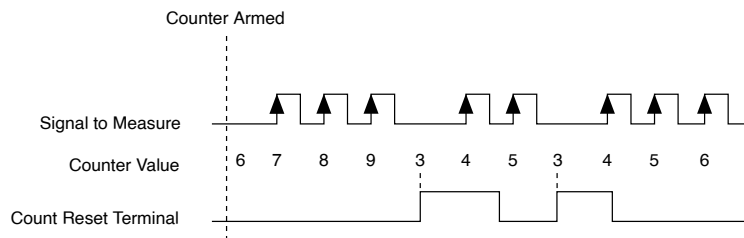

The following figure shows an example of edge counting with Count Edges Pause Trigger level set to high.

Figure 5. Count Edges Pause Trigger

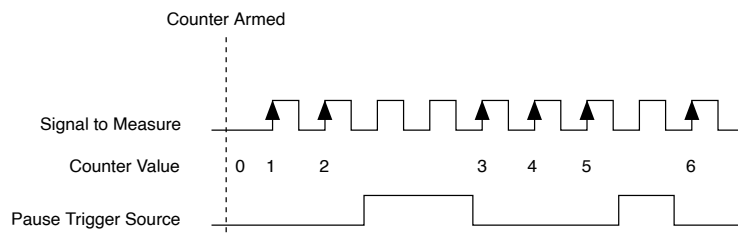

Trigger Settings

Counter Arm—You can control when the counter starts counting through the counter arm control. The counter waits for the active edge on the signal-to-measure after it is armed, and counts on every active edge on the signal-to-measure. Refer to your software documentation for more information on arming the counter.

Pulse/Duty Cycle Measurement

The NI 9361 supports pulse measurements only for CompactRIO systems.

You can take pulse or duty cycle measurements with the NI 9361. The counter measures the high and low durations of a pulse on a signal. Using the measured values, you can calculate the duty cycle of the signal. The NI 9361 returns the current measurement values when the counter is read. The measurement values consist of the high and low times of the pulse in the number of ticks of the 100 MHz counter timebase.

You can calculate the signal period using the following equation:

$$\text{Signal Period} = T_{\text{pulsehigh}} + T_{\text{pulselow}}$$

where

- $T_{\text{pulsehigh}}$ is the pulse high time
- T_{pulselow} is the pulse low time

You can calculate the duty cycle using the following equation:

$$\text{Duty Cycle} = \frac{T_{\text{pulsehigh}}}{\text{Signal Period}}$$

The following figure shows an example of pulse measurement.

Figure 6. Pulse Measurement

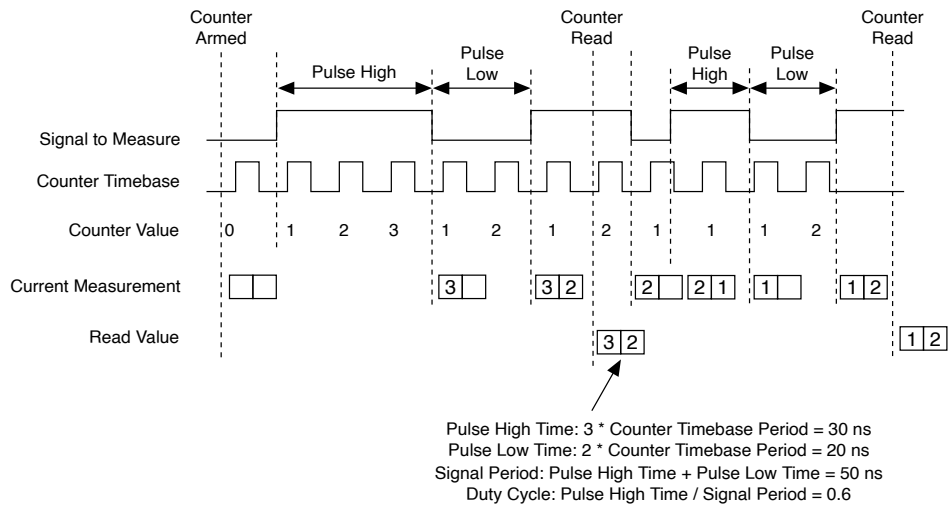

Channel Settings

You can configure the following counter properties:

- Input terminal of the signal-to-measure.
- The active edge, rising or falling, the NI 9361 begins the measurement.
- Maximum measurable period.
 - You can set the maximum measurable period of the signal. If the input signal period is slower than this value, the counter returns a measurement value of zero. Use this property to get updated measurement data when the signal slows down or is stopped instead of previous measurements. To disable this feature, set the maximum measurable period to zero. When this feature is disabled, the counter keeps measuring until a valid measurement is detected, the counter overflows, or the user stops the counter.

Trigger Settings

Counter Arm — You can control when the counter starts the pulse measurement through the counter arm control. After the counter is armed, it waits for the active edge on the signal-to-measure, and then it begins measuring the signal high and low times. The measurement data is only ready and valid once the counter has

finished measuring the first signal period. The counter returns a value of zero for both the high and low times prior to the first measurement becoming ready. Refer to your software documentation for more information on arming the counter.

Frequency/Period Measurement

You can take frequency or period measurements with the NI 9361. The counter measures and returns the period information of a signal. The NI 9361 supports a few frequency measurement methods depending on the settings set by the user. The NI 9361 returns the current period measurement values when the counter is read. The measurement values consist of the number of full periods of the signal-to-measure measured and also the duration of these full periods in the number of ticks of the 100 MHz counter timebase.

You can calculate the signal period using the following equation:

$$\text{Signal Period} = \frac{N_{\text{ticks}} \times T_{\text{base}}}{N_{\text{periods}}}$$

where

- T_{base} is the counter timebase period which is 10 ns
- N_{ticks} is the number of ticks of the counter timebase that elapsed during the measurement
- N_{periods} is the number of full periods of the signal-to-measure measured

You can calculate the frequency using the following equation:

$$\text{Signal Frequency} = \frac{1}{\text{Signal Period}}$$

Channel Settings

You can configure the following counter properties:

- Input terminal of the signal-to-measure.
- The active edge, rising or falling, the NI 9361 begins the measurement.
- Maximum measurable period.

- You can set the maximum measurable period of the signal. If the input signal period is slower than this value, the counter returns a measurement value of zero. Use this property to get updated measurement data when the signal slows down or is stopped instead of previous measurements. To disable this feature, set the maximum measurable period to zero. When this feature is disabled, the counter keeps measuring until a valid measurement is detected, the counter overflows, or the user stops the counter.

Measurement Method

You can configure the following properties to configure the frequency measurement method:

- Divisor
 - Divisor specifies the number of periods of the input signal to measure to determine the average input signal period.
- Measurement Time
 - Measurement Time specifies the amount of time over which to measure and average multiple periods of the input signal. In this measurement mode, the counter measures how ever many periods of the input signal fit within the specified Measurement Time.
- Both the Divisor and Measurement Time
 - When both the Divisor and the Measurement Time values are set, the counter goes into Dynamic Averaging mode. In this mode, the counter simultaneously performs the measurement based on both the Divisor and Measurement Time settings, and returns whichever measurement completes first.

The following figure shows an example of setting the Divisor to 1 for the frequency measurement.

Figure 7. Measurement with Divisor set to 1

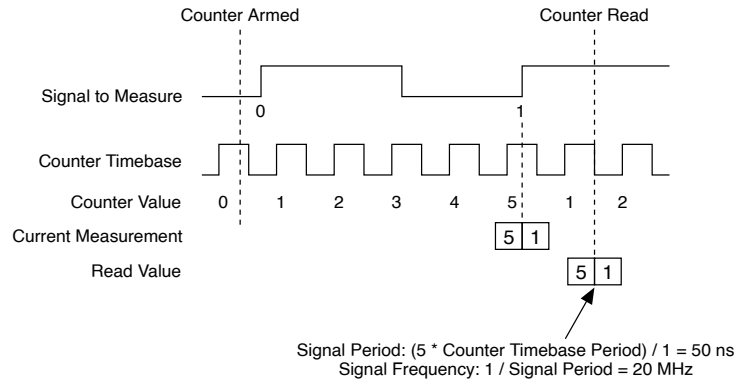

The following figure shows an example of setting the Divisor to 3 for the frequency measurement.

Figure 8. Measurement with Divisor set to 3

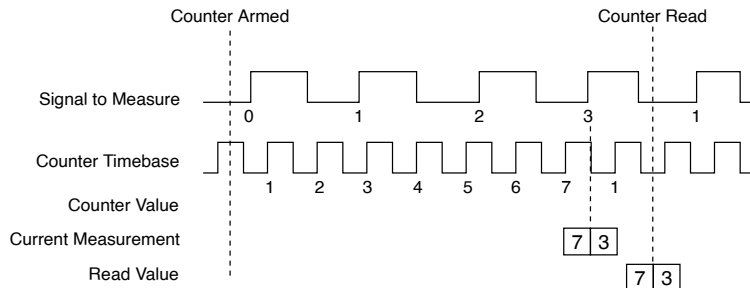

The following figure shows an example of Measurement Time.

Figure 9. Measurement using Measurement Time

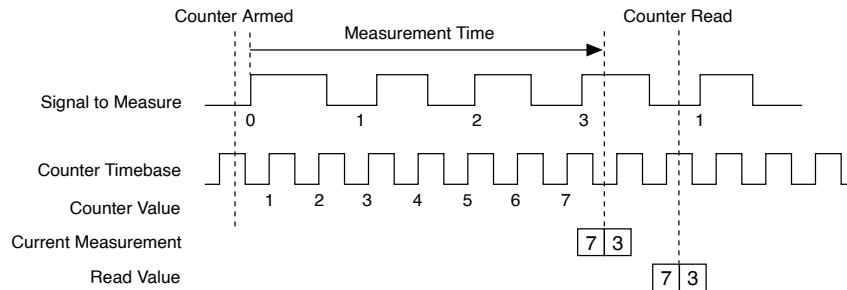

In the following examples, both the Divisor and Measurement Time are set for frequency measurement.

In the following figure, the Divisor period of the input signal, in this case 3, is met before the measurement time elapsed, thus the Divisor setting is used for the frequency measurement.

Figure 10. Divisor completes before Measurement Time

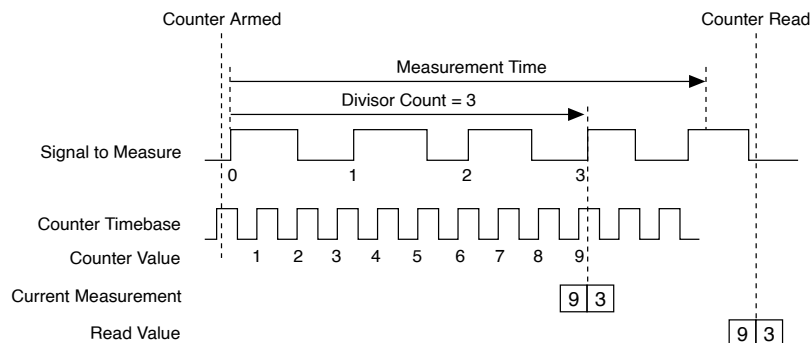

In the following figure, the measurement time elapsed before the 3 divisor periods of the input signal, thus the Measurement Time setting is used for the frequency measurement.

Figure 11. Measurement Time completes before Divisor

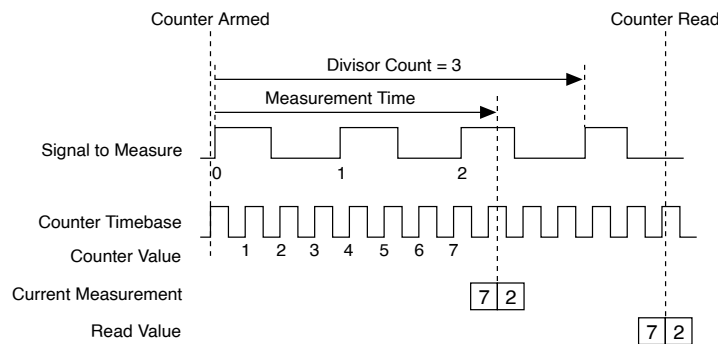

The following table shows the summary of different frequency measurement methods.

Divisor	Measurement Time	Counter Characteristic
1	0 (Disabled)	Measure 1 period of the input signal.
N	0 (Disabled)	Measure N periods of the input signal.

Divisor	Measurement Time	Counter Characteristic
0 (Disabled)	M	Measures all the period of the input signals that occur within the M measurement time.
N	M	Returns the measurement of N periods of the input signal or the measurement that occurs within the M measurement time, whichever completes first.

Trade-offs—Different frequency methods are used to trade-off between measurement accuracy and measurement update rate for different input signal frequencies. Increasing the divisor or measurement time improves the measurement accuracy but also reduces the measurement rate.

Measurement Error—Measurement error is caused by the uncertainty in measuring the frequency of the input signal due to the finite resolution of the counter timebase clock.

You can calculate the maximum error using the following equation:

$$\text{Measurement Error}(\%) = \frac{f_x}{(N_{\text{periods}} \times f_k) - f_x} \times 100\%$$

where

- f_x is the frequency of the input signal
- N_{periods} is the number of signal periods measured
- f_k is the counter timebase frequency

You can calculate the maximum frequency error using the following equation:

$$\text{Measurement Frequency Error}(\text{Hz}) = f_x \times \frac{f_x}{(N_{\text{periods}} \times f_k) - f_x}$$

For example, when measuring the frequency of a 1 MHz input signal with the divisor count of 10, and the counter timebase of 100 MHz, the maximum error is

$$\frac{1 \text{ MHz}}{(10 \times 100 \text{ MHz}) - 1 \text{ MHz}} \times 100\% = 0.1\%$$

The maximum frequency error is

$$1 \text{ MHz} \times \frac{1 \text{ MHz}}{(10 \times 100 \text{ MHz}) - 1 \text{ MHz}} = 0.001 \text{ MHz}$$

The resulting measured frequency is $1 \text{ MHz} \pm 0.001 \text{ MHz}$.



Note This error does not include the error introduced by the timebase accuracy.

Trigger Settings

Counter Arm—You can control when the counter starts the frequency measurement through the counter arm control. After the counter is armed, it waits for the active edge on the signal-to-measure, and then it begins measuring the signal period. The measurement data is only ready and valid once the counter has finished measuring the first measurement according to the Divisor and Measurement Time settings. The counter returns a value of zero for both the N_{ticks} and N_{periods} times prior to the first measurement becoming ready. Refer to your software documentation for more information on arming the counter.

Pulse Width Measurement

You can take pulse width measurements with the NI 9361. The counter measures and returns the duration of a pulse on a signal. The NI 9361 returns the current pulse width measurement value when the counter is read. The measurement values consist of the pulse width duration of the signal-to-measure in the number of ticks of the 100 MHz counter timebase. The following figure shows an example of pulse width measurement.

Figure 12. Pulse Width Measurement

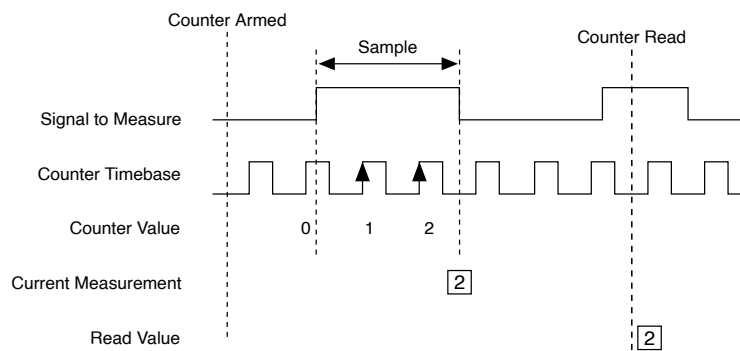

Channel Settings

You can configure the following counter properties:

- Input terminal of the signal-to-measure.
- The active edge, rising or falling, the NI 9361 begins the measurement. To measure a high pulse, set the active edge to rising. To measure a low pulse, set the active edge to falling.
- Maximum measurable period.
 - You can set the maximum measurable period of the signal. If the input signal period is slower than this value, the counter returns a measurement value of zero. Use this property to get updated measurement data when the signal slows down or is stopped instead of previous measurements. To disable this feature, set the maximum measurable period to zero. When this feature is disabled, the counter keeps measuring until a valid measurement is detected, the counter overflows, or the user stops the counter.

Trigger Settings

Counter Arm—You can control when the counter starts the pulse width measurement through the counter arm control. After the counter is armed, it waits for the active edge on the signal-to-measure, and then it begins measuring the pulse width. The measurement data is only ready and valid once the counter has finished measuring the first pulse width. The counter returns a value of zero prior to the first measurement becoming ready. Refer to your software documentation for more information on arming the counter.

Two-Edge Separation Measurement

The NI 9361 supports two-edge separation measurements only for CompactRIO systems.

You can take two-edge separation measurements with the NI 9361. The counter measures the time between two events. The beginning event is an active edge on a first signal. The ending event is an active edge on a second signal. The NI 9361

returns the current time between the two events in the number of ticks of the 100 MHz counter timebase when the counter is read. The following figure shows an example of two-edge separation measurement.

Figure 13. Two-Edge Separation

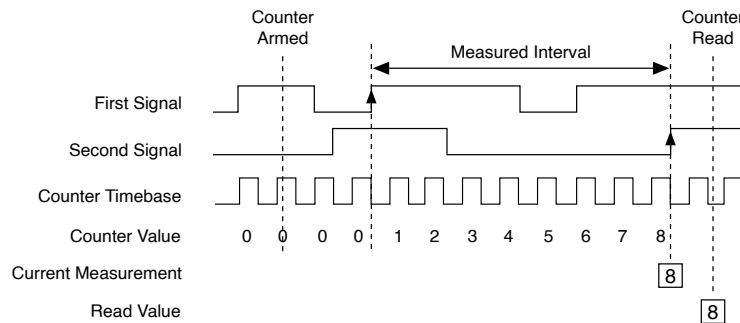

Channel Settings

You can configure the following counter properties:

- Input terminal of the first signal.
- Input terminal of the second signal.
- The active edge of the first signal, rising or falling, the NI 9361 begins the measurement.
- The active edge of the second signal, rising or falling, the NI 9361 ends the measurement.
- Maximum measurable separation.
 - You can set the maximum measurable separation of the signals. If separation time between the first and second signals is longer than this value, the counter returns a measurement value of zero. Use this property to get updated measurement data when the signal slows down or is stopped instead of returning previous measurements. To disable this feature, set the maximum measurable separation to zero. When this feature is disabled, the counter keeps measuring until a valid measurement is detected, the counter overflows, or the user stops the counter.

Trigger Settings

Counter Arm—You can control when the counter starts the two-edge separation measurement through the counter arm control. After the counter is armed, it waits for the active edge on the first signal, and then it begins measuring the separation. The measurement data is only ready and valid once the counter has finished measuring the separation between the first and second edges. The counter returns a value of zero prior to the first measurement becoming ready. Refer to your software documentation for more information on arming the counter.

Incremental Encoder Measurements

The NI 9361 can perform position and velocity measurements using incremental encoders, such as the quadrature and two-pulse encoders.

Quadrature Encoder Overview

A quadrature encoder can have up to three channels: A, B, and Z. When channel A leads channel B in a quadrature cycle, the counter increments. When channel B leads channel A in a quadrature cycle, the counter decrements. The amount of increments and decrements per cycle depends on the type of encoding: X1, X2, or X4.

- X1 Encoding**—The following figure shows a quadrature cycle and the resulting increments and decrements for X1 encoding. When channel A leads channel B, the increment occurs on the rising edge of channel A. When channel B leads channel A, the decrement occurs on the falling edge of channel A.

Figure 14. X1 Encoding

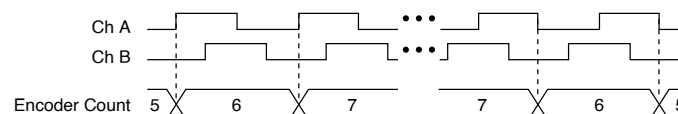

- X2 Encoding—The counter increments or decrements on each edge of channel A, depending on which channel leads the other. Each cycle results in two increments or decrements, as shown in the following figure.

Figure 15. X2 Encoding

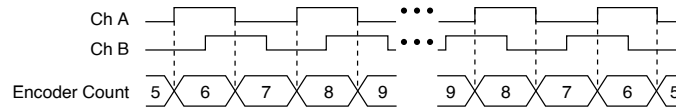

- X4 Encoding—The counter increments or decrements on each edge of channels A and B. Whether the counter increments or decrements depends on which channel leads the other. Each cycle results in four increments or decrements, as shown in the following figure.

Figure 16. X4 Encoding

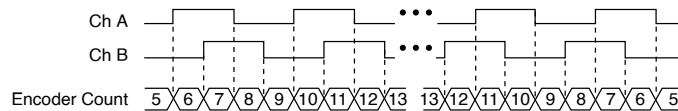

Some quadrature encoders have a third channel, channel Z, which is also referred to as the index channel. A high level on channel Z causes the counter to be reloaded with a specified value in a specified phase of the quadrature cycle. Depending on configuration, this reload can occur in any one of the four phases in a quadrature cycle.

Channel Z behavior-when it goes high and how long it stays high-differs with quadrature encoder designs. Refer to the documentation for your quadrature encoder to obtain timing of channel Z with respect to channels A and B. You must then ensure that channel Z is high during at least a portion of the phase you specify for reload.

In the following figure, the reload phase is when both channel A and channel B are low. The reload occurs when this phase is true and channel Z is high. Thus, when channel B goes low to enter the reload phase, the reload occurs. After the reload occurs, the counter continues to count as before. The figure illustrates channel Z reload with X4 decoding.

Figure 17. Channel Z Reload

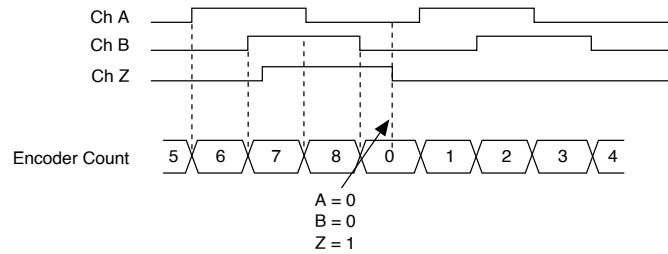

Two-Pulse Encoder Overview

The counter supports two-pulse encoders that have two channels: A and B. The counter increments on each rising edge of channel A. The counter decrements on each rising edge of channel B, as shown in the following figure.

Figure 18. Two-Pulse Encoder

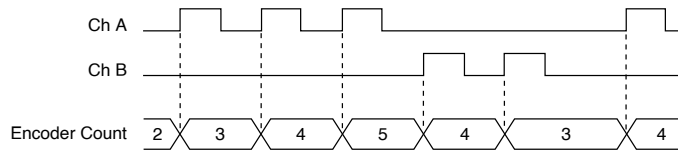

Position Measurement

You can take position measurements with the NI 9361. The counter measures position using an encoder. The NI 9361 returns the current encoder count value when the counter is read. The following figure shows an example of an encoder position measurement using a Quadrature Encoder.

Figure 19. Quadrature Encoder Position Measurement

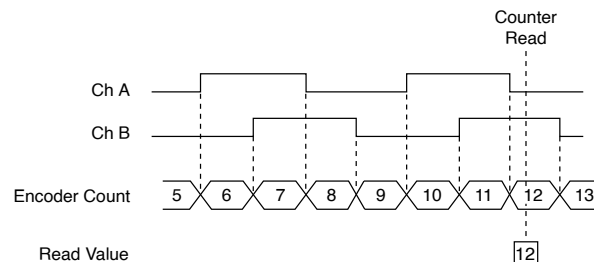

The following figure shows an example of Two-Pulse Encoder position measurement.

Figure 20. Two-Pulse Encoder Position Measurement

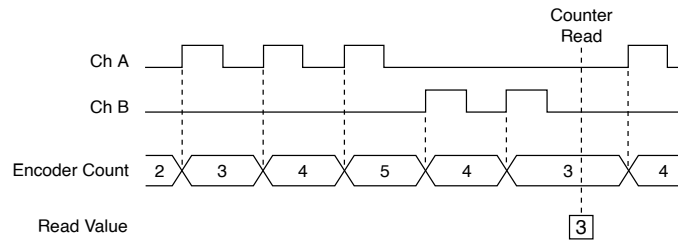

Channel Settings

You can configure the following counter properties:

- Decoding Type: Configurable to two-pulse decoding for two-pulse encoder or X1, X2 or X4 decoding for quadrature encoder.
- Input terminal of A signal.
- Input terminal of B signal.
- The initial value of the count.

You can configure the following counter properties for encoders supporting Z terminal:

- Z index enable to enable the reset of the counter based on the Z signal.
- Input terminal of Z signal.
- Z index phase for quadrature encoders to indicate when to reset the counter.
- Z index value to indicate the value to reset the counter to.

Trigger Settings

Counter Arm—You can control when the counter starts the encoder position measurement through the counter arm control. The counter waits for the active edge on the encoder signal after it is armed and starts counting after it is detected. Refer to your software documentation for more information on the arming of the counter.

Velocity Measurement

You can take velocity measurements with the NI 9361. The counter measures the amount of time that elapses between changes in the encoder count value. The concept is similar to a period measurement and the counter supports the same Measurement Time and Divisor settings described for period measurement mode. Refer to the [Frequency/Period Measurement](#) section for detailed information about these settings.

The measurement value consists of the number of changes to the encoder count value and the duration of these changes measured by the number of 100 MHz counter timebase ticks. The encoder count value is returned as a signed number where the sign of the number corresponds to the direction of movement.

You can calculate the encoder velocity using the following equation:

$$\text{Encoder Count Velocity (Counts/s)} = \frac{N_{\text{counts}}}{N_{\text{ticks}} \times T_{\text{base}}}$$

where

- N_{counts} is the signed number of encoder count periods measured
- N_{ticks} is the number of ticks of the counter timebase that elapsed during the measurement
- T_{base} is the counter timebase period of 10ns

For encoder velocity measurements using a quadrature encoder, when A leads B, a positive value is returned. When B leads A, a negative value is returned. The following figure shows an example of velocity measurement using an X4 encoding type quadrature encoder. The Divisor count is set to 1 and the Measurement Time is disabled.

Figure 21. Quadrature Encoder Velocity Measurement

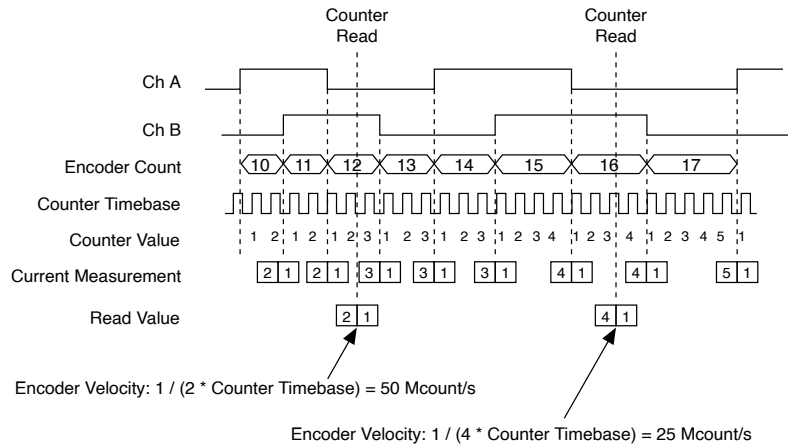

For a two-pulse encoder, when a pulse is detected on Channel A, a positive value is returned. When a pulse is detected on Channel B, a negative value is returned. The following figure shows an example of velocity measurement using a two-pulse encoder. The Divisor count is set to 1 and the Measurement Time is disabled.

Figure 22. Two-Pulse Encoder Velocity Measurement

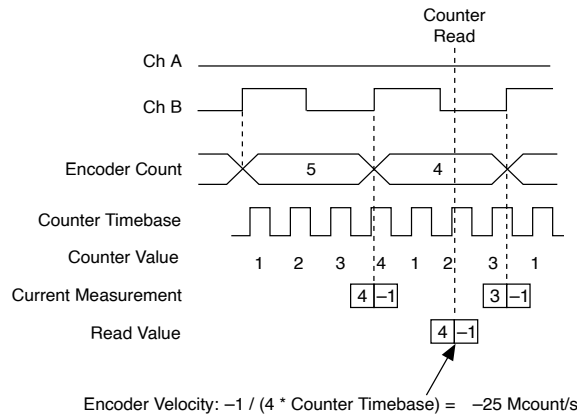

Channel Settings

You can configure the following counter properties:

- Decoding Type: Configurable to two-pulse decoding for two-pulse encoder or X1, X2 or X4 decoding for quadrature encoder.
- Input terminal of A signal.
- Input terminal of B signal.

- Maximum Measurable Count Period.
 - You can set the maximum measurable count period of the signal. If the encoder count value changes slower than this value, the counter returns a measurement value of zero for both N_{ticks} and N_{counts} . Use this property to get updated measurement data when the encoder slows down or is stopped instead of previous measurements. To disable this feature, set the Maximum Measurable Count Period to zero. When this feature is disabled, the counter keeps measuring until a valid measurement is detected, the counter overflows, or the user stops the counter.

Measurement Method

You can configure the following properties to configure the encoder velocity measurement method:

- Divisor
- Measurement Time
- Both the Divisor and Measurement Time

Refer to the [Frequency/Period Measurement](#) section for detailed information about these settings.

Trigger Settings

Counter Arm—You can control when the counter starts the encoder velocity measurement through the counter arm control. After the counter is armed, it waits for the active edge on the encoder signal, and then it begins measuring the encoder velocity. The measurement data is only ready and valid once the counter has finished measuring the first measurement according to the Divisor and Measurement Time settings. The counter returns a value of zero for both the N_{ticks} and N_{counts} times prior to the first measurement becoming ready. Refer to your software documentation for more information on arming the counter.

NI 9361 Counter Signal Routing

The NI 9361 has flexible signal routing features. The input signals to the counters can be routed from any of the eight digital input terminals. You can change the signal routing by configuring the counter properties.

The software routes certain digital input signals to each of the counters by default. The following table shows the default routing for counter signals.

Measurement	Signal	Counter							
		0	1	2	3	4	5	6	7
Edge Counting	Source	DI0	DI1	DI2	DI3	DI4	DI5	DI6	DI7
	Reset	DI4	DI5	DI6	DI7	DI0	DI1	DI2	DI3
	Count Direction	DI7	DI6	DI5	DI4	DI3	DI2	DI1	DI0
	Pause Trigger	DI3	DI2	DI1	DI0	DI7	DI6	DI5	DI4
Pulse/Duty Cycle	Source	DI0	DI1	DI2	DI3	DI4	DI5	DI6	DI7
Pulse Width	Source	DI0	DI1	DI2	DI3	DI4	DI5	DI6	DI7
Period/Frequency	Source	DI0	DI1	DI2	DI3	DI4	DI5	DI6	DI7
Two-Edge Separation	1st Edge	DI0	DI1	DI2	DI3	DI4	DI5	DI6	DI7
	2nd Edge	DI4	DI5	DI6	DI7	DI0	DI1	DI2	DI3
Encoder Position	A	DI0	DI1	DI2	DI3	DI4	DI5	DI6	DI7
	B	DI4	DI5	DI6	DI7	DI0	DI1	DI2	DI3
	Z/Reset	DI7	DI6	DI5	DI4	DI3	DI2	DI1	DI0
Encoder Velocity	A	DI0	DI1	DI2	DI3	DI4	DI5	DI6	DI7
	B	DI4	DI5	DI6	DI7	DI0	DI1	DI2	DI3

Table 1. Default Routing for Counter Signals

NI 9361 Specifications

The following specifications are typical for the range -40 °C to 70 °C unless otherwise noted.



Caution Do not operate the NI-9361 in a manner not specified in this document. Product misuse can result in a hazard. You can compromise the

safety protection built into the product if the product is damaged in any way. If the product is damaged, return it to NI for repair.

Input Characteristics

Number of inputs	8
Input type, programmable per line	Differential, single-ended with pull-up or single-ended without pull-up
I/O signal rate	1 MHz maximum
Digital line filtering settings, programmable per line	0 ns (disabled) to 5.24 ms in 80 ns steps
Digital logic levels	
Differential(DI+ - DI-)	
Input voltage range (DI+ and DI-)	0 V to 5 V
Input high range	200 mV to 5 V
Input low range	-200 mV to -5 V
Hysteresis	None
Single-ended (DI+)	
Input voltage range (DI+)	0 V to 24 V
Programmable input threshold range	1 V to 4 V
Input threshold error	12% maximum

Input threshold resolution	20 mV
Hysteresis	500 mV
Internal pull-up settings, programmable per line	Enabled or disabled
Internal pull-up voltage	5 V
Maximum input current	
With 5 V input (DI+ or DI-)	50 μ A maximum per input terminal
With 24 V input (DI+)	1.5 mA maximum per input terminal
I/O protection	
Input voltage (channel-to-COM), on 8 DI+ terminals simultaneously	+30 V
Input voltage (channel-to-COM), on two pairs of DI+ and DI- terminals at a time	\pm 30 V
Input current on DI+	\pm 2.3 mA maximum at \pm 30V overvoltage
Input current on DI-	\pm 3 mA maximum at \pm 30V overvoltage
Input propagation delay	310 ns maximum
Input channel-to-channel skew	220 ns maximum
Input pulse width distortion	160 ns maximum

Counter Features

Number of counters	8 counters
Resolution	32 bits
Sample rate	102.4 kHz maximum
Counter measurements	Edge counting, pulse ^[1] , pulse width, period, frequency, duty-cycle and two-edge separation ^[1]
Encoder measurements	Velocity ^[1] and position
Encoder support	Incremental encoders with two-pulse or quadrature encoding (and optional Z index reloading)
Internal timebase	100 MHz
Timebase accuracy	±50 ppm maximum
Input routing	Any DI can drive any counter input

Power Requirements

Maximum power consumption from chassis

Active mode 0.92 W maximum

Sleep mode 53 µW maximum

Maximum thermal dissipation (at 70 °C)

Active mode 1.20 W maximum

Sleep mode	0.46 W maximum
------------	----------------

External Power Supply (VSUP)

Input voltage	30 V DC maximum
---------------	-----------------

Current	1 A maximum
---------	-------------



Note The NI 9361 does not provide overvoltage protection for external power supply connection.

Physical Characteristics

Dimensions	Visit ni.com/dimensions and search by module number.
Weight	146 g (5.15 oz)

Safety Voltages

Connect only voltages that are within the following limits:

Isolation

Channel-to-channel	None
--------------------	------

Channel-to-earth ground (up to 3000 m)

Continuous	60 V DC, Measurement Category I
------------	---------------------------------

Withstand	1,000 V RMS, verified by a 5 s dielectric withstand test
-----------	--

Vsup inputs-to-earth ground (up to 3000 m)

Continuous	60 V DC, Measurement Category I
Withstand	1,000 V RMS, verified by a 5 s dielectric withstand test

Channel-to-earth ground (up to 5000 m)

Continuous	60 V DC, Measurement Category I
Withstand	860 V RMS, verified by a 5 s dielectric withstand test

Vsup inputs-to-earth ground (up to 5000 m)

Continuous	60 V DC, Measurement Category I
Withstand	860 V RMS, verified by a 5 s dielectric withstand test



Note Measurement Categories CAT I and CAT O are equivalent. These test and measurement circuits are for other circuits not intended for direct connection to the MAINS building installations of Measurement Categories CAT II, CAT III, or CAT IV.

Hazardous Locations

U.S. (UL)	Class I, Division 2, Groups A, B, C, D, T4; Class I, Zone 2, AEx nA IIC T4 Gc
Canada (C-UL)	Class I, Division 2, Groups A, B, C, D, T4; Ex nA IIC T4 Gc
Europe (ATEX) and International (IECEX)	Ex nA IIC T4 Gc DEMKO 12 ATEX 1202658X IECEX UL 14.0089X

Safety Compliance and Hazardous Locations Standards

This product is designed to meet the requirements of the following electrical equipment safety standards for measurement, control, and laboratory use:

- IEC 61010-1, EN 61010-1
- UL 61010-1, CSA C22.2 No. 61010-1
- EN 60079-0, EN 60079-7
- IEC 60079-0, IEC 60079-7
- UL 60079-0, UL 60079-7
- CSA C22.2 No. 60079-0, CSA C22.2 No. 60079-7



Note For safety certifications, refer to the product label or the [Product Certifications and Declarations](#) section.

Electromagnetic Compatibility

CE Compliance

- 2014/34/EU; Potentially Explosive Atmospheres (ATEX)

Product Certifications and Declarations

Refer to the product Declaration of Conformity (DoC) for additional regulatory compliance information. To obtain product certifications and the DoC for NI products, visit ni.com/product-certifications, search by model number, and click the appropriate link.

Shock and Vibration

To meet these specifications, you must panel mount the system.

Operating vibration	
Random	5 g RMS, 10 Hz to 500 Hz
Sinusoidal	5 g, 10 Hz to 500 Hz
Operating shock	30 g, 11 ms half sine; 50 g, 3 ms half sine; 18 shocks at 6 orientations

Environmental

Refer to the manual for the chassis you are using for more information about meeting these specifications.

Operating temperature (IEC 60068-2-1, IEC 60068-2-2)	-40 °C to 70 °C
Storage temperature (IEC 60068-2-1, IEC 60068-2-2)	-40 °C to 85 °C
Ingress protection	IP40
Operating humidity (IEC 60068-2-30)	10% RH to 90% RH, noncondensing
Storage humidity (IEC 60068-2-30)	5% RH to 95% RH, noncondensing
Pollution Degree	2
Maximum altitude	5,000 m

Indoor use only.

Environmental Management

NI is committed to designing and manufacturing products in an environmentally responsible manner. NI recognizes that eliminating certain hazardous substances from our products is beneficial to the environment and to NI customers.

For additional environmental information, refer to the **Engineering a Healthy Planet** web page at ni.com/environment. This page contains the environmental regulations and directives with which NI complies, as well as other environmental information not included in this document.

EU and UK Customers

-  **Waste Electrical and Electronic Equipment (WEEE)**—At the end of the product life cycle, all NI products must be disposed of according to local laws and regulations. For more information about how to recycle NI products in your region, visit ni.com/environment/weee.

电子信息产品污染控制管理办法（中国 RoHS）

-  **中国 RoHS**—NI 符合中国电子信息产品中限制使用某些有害物质指令(RoHS)。关于 NI 中国 RoHS 合规性信息，请登录 ni.com/environment/rohs_china。(For information about China RoHS compliance, go to ni.com/environment/rohs_china.)

¹ The NI 9361 supports this measurement only for CompactRIO systems.